



Operators for
sliding gates
of up to
800 Kg / 1,760 lb



Gate operators tested
in compliance with
European
Standards on the
subject of impact
force.

Bx

The “customisable” operator

The Bx series offers a vast range of operators for all sliding gates weighing up to 800 Kg.

It is a complete series, which best meets the diverse operational and safety requirements.



CAME
AUTOMATIC GATES

Bx_{230V 24V}

Extremely practical and completely safe

Bx is the right solution when automating sliding gates. Thanks to highest levels of efficiency and safety provided by the control boards, Bx is suited for numerous application contexts, both in residential and apartment block settings. The series also offers several 24V versions to be used for intense work loads, and is ideal where there are frequent power outages.



Exclusively practical.

BX-P is the version featuring the PRATICO SYSTEM – the user-friendly Came PATENTED device which, in the event of blackouts, releases the gearmotor through the transmitter no need to search for any keys.

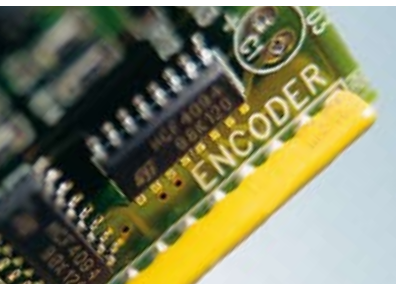

Encoder technology.

The gate's movement is electronically controlled, and it is safe and constant, giving you total peace-of-mind and safety when using it.



True comfort.

In the event of a blackout, the electronics of the 24V versions immediately activates the emergency mode through the batteries (optional).

Safety even when the gate is not in motion.

If the safety devices detect an obstacle, every command is ignored.

Movement control.

Bx enables you to arrest the gate directly from the transmitter, giving you total control of the system.

EN12445 - EN12453 compliant.

The built-in panel of the BX-74 constantly controls the door's movement allowing for safe thrust, and is EU standard compliant.



Easier and safer operation.

Bx is fitted to take and control auxiliary lighting, which turns on every time the gate is opened, thus making the access easier and safer.

Designed to last over time.

The high degree of sturdiness of all the components provides maximum endurance against the atmospheric agents.

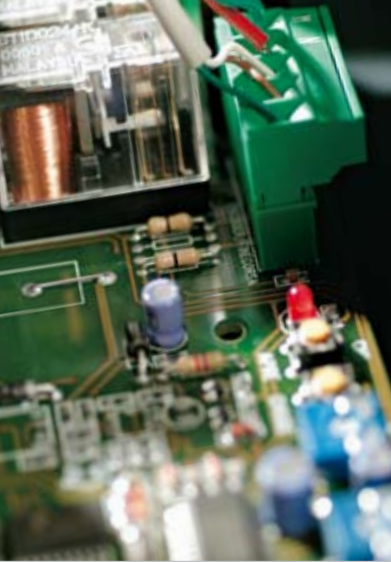

The 230V electronics

Besides the usual control and safety functions, Bx's 230V electronics provide certain details that allow for total control of the operator and optimal working conditions of the same. Here are some examples:

- > **Total control of the gate from the transmitter**
including the possibility of immediately stopping the movement of the gate leaves.
- > **Partial opening**
of the gate to allow pedestrian passage.
- > **Safety even when the gate is not moving thanks to the special electronic circuit**
which ignores every command if an obstacle is detected by the safety devices.

The advantages of the 24V Bx

When the highest degree of comfort, performance and safety are required, Bx's 24V technology elevates the potential of the operator, particularly:

- > **No more blackouts**
The 24V electronics automatically detect any absence of power and activate the emergency back up batteries, to open and close the gate.
- > **Frequent passages**
The low-voltage gearmotor guarantees functioning even in the harshest of working conditions, such as in apartment blocks and in other collective settings.
- > **Quick openings**
Adaptable to all needs, the 24V electronics enable the adjustment of the working speed of the gate leaves and provide for a smooth, soft closing as well.
- > **Obstacle detection**
A special electronic circuit constantly sweeps for any obstacles to the gate leaves, and if needed stops or inverts the direction of movement.



Standard installation

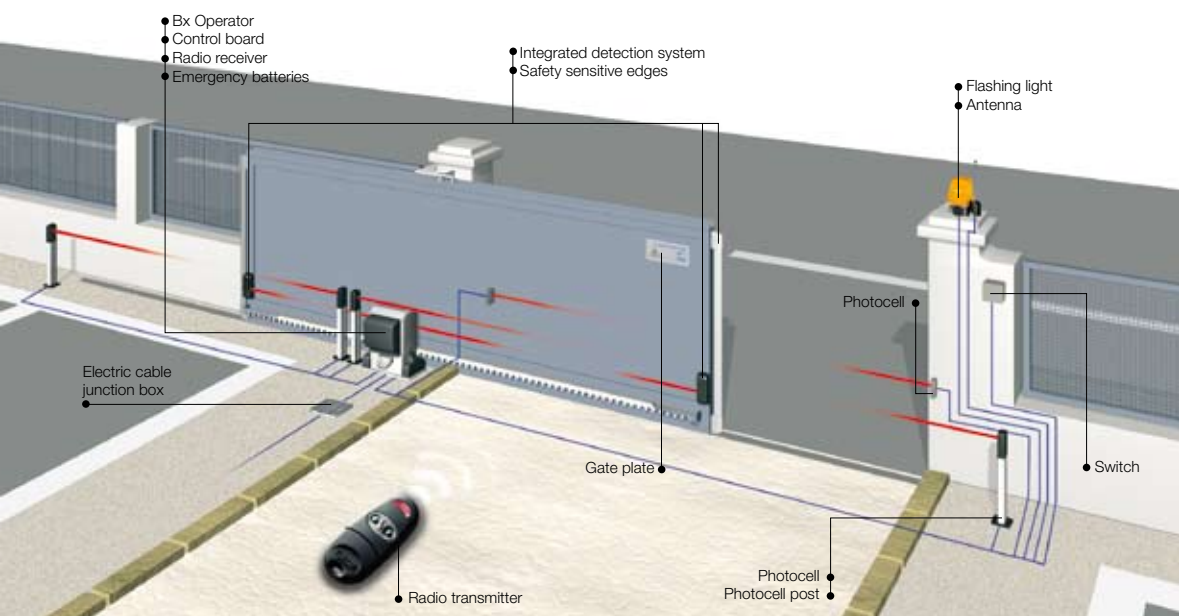

In the event a careful analysis of the automated gate's risks were to require it, the use of sensitive safety infrared or contact edges becomes indispensable.

Made in Italy

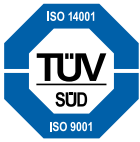

For its quality processes management Came Cancelli Automatici is ISO 9001:2000 certified, and for its environmental management it is ISO 14001 certified. Came designs and manufactures entirely in Italy.

The range

Complete automation system with 230V A.C. motor

BX-74 Automation system complete with control board, radio decoder, encoder-based movement control and obstacle detection devices. Plus, mechanical endstops for sliding gates of up to 400 Kg / 880 lb.



Complete automation system with 230V A.C. motor

BX-78 Automation system complete with control board, radio decoder, encoder-based movement control and obstacle detection devices. Plus, mechanical endstops for sliding gates of up to 800 Kg / 1,760 lb.

BX-10 Automation system complete with control board featuring function programming display, built-in radio decoder, encoder-based movement control device and obstacle detection for sliding gates of up to 800 Kg / 1,760 lb in weight and 14 m / 45.93 ft in length.

BX-P Automation system complete with control board, built-in radio decoder and PRATICO SYSTEM radio release system with a 12V - 1.2 Ah battery for gates weighing up to 600 Kg / 1,320 lb. (notes)



Complete automation system with 24V D.C. motor

BX-246 Automation system complete with control board, radio decoder, encoder-based movement control and obstacle detection devices. Plus, mechanical endstops for sliding gates of up to 600 Kg / 1,320 lb. Fitted to take two 12V - 1.2 Ah batteries.



Accessories

RO01 Lock cylinder with DIN key.

B4337 Chain transmission device.

CCT 1/2 in simple chain for B4337.

CGIU Joint for 1/2" in chain.

LBD2 Card for connecting two 12V - 1.2Ah emergency batteries for 12 BX-246.

RSE Synchronised function management card for BX-10

CGZ Galvanized rack in rolled steel 22 x 22 mm / 0.86 x 0.86 in module 4.

CGZP Rack in PA6 nylon and fibreglass with steel core 20 x 20 mm / 0.78 x 0.78 in module 4, with securing holes and distancers, for sliding gates of up to 300 Kg / 661 lb.

CGZS Galvanized rack in rolled steel 30 x 8 mm / 1.18 x 0.31 in module 4 with securing holes and distancers.



PRODUCTS



Technical features

Type	BX-74	BX-P	BX-246	BX-10	BX-78
Protection rating	IP54	IP54	IP54	IP54	IP54
Power supply (V) (50/60Hz)	230 A.C.	230 A.C.	230 A.C.	230 A.C.	230 A.C.
Motor power supply (V)	230 A.C. (50/60 Hz)	230 A.C. (50/60 Hz)	24 D.C.	230 A.C. (50/60 Hz)	230 A.C. (50/60 Hz)
Current draw (A)	2.6	2	10 Max	2.4	2.4
Power (W)	200	230	400	300	300
Manoeuvre speed (m/min - ft/s)	10/0.54	17/0.92	6/0.33 ±12/0.65	10.5/0.57	10.5/0.57
Duty cycle (%)	30	30		30	30
Thrust (N)	300	600	700	800	800
Motor's thermo-protection (°C/°F)	150 / 302	150 / 302	-	150 / 302	150 / 302
Operating temperature (°C/°F)	-20 - +55 / -4 - +131				

120V A.C. - 60 Hz PRODUCTS, PLEASE CHECK OUR PRICE LIST

● 230V A.C. ● 24V D.C.

Limits to use

Model	BX-74	BX-P	BX-246	BX-10	BX-78
Max weight of gate leaf (Kg/lb)	400 / 880	600 / 1,320	600 / 1,320	800 / 1,760	800 / 1,760
Max length of gate leaf (m / ft)	14 / 45.93	14 / 45.93	18 / 59.05	20 / 65.61	14 / 45.93

● 230V A.C. ● 24V D.C.

Dimensions

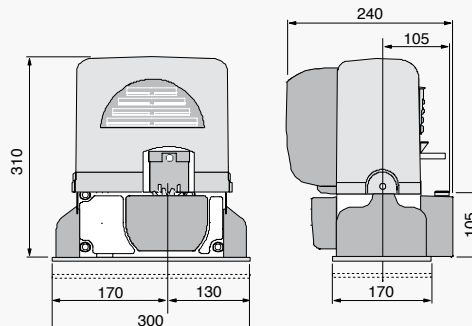

© Came KDEP#CEN04A3S10408 - 4/09

Came
cancelli automatici
S.p.A.

via Martiri della Libertà, 15
31030 Dosson di Casier
Treviso - ITALY
www.came.com - info@came.it

The data and information shown in this catalogue are subject to change without the obligation to give prior notice by Came cancelli automatici S.p.A.

